

EL+ vAC/DC Full



Regenerative AC/DC Electronic Load

CINERGIA's EL+ vAC/DC is the most versatile regenerative Current Source in the market for energy testing in AC and DC applications. Thanks to its flexibility, this device becomes crucial for testing and R&D purposes in Smartgrids, Renewable Energy, Storage Systems, Electromobility, Avionics and Power HiL. Moreover, its regenerative hardware allows saving energy and power.

Key features

Bidirectional and Regenerative
Clean grid current: THDi < 3% and PF > 0.98
Same Power in DC and AC

13 models from 7.5kW to 160kW
Parallelization of units to increase the power

Emulation of grid-connected devices:
Loads absorbing energy from grid.
Generators injecting energy to the grid.
Programmable Active/Reactive consumption
Non-linear currents up to CF of 3

Independent phase configuration of:
rms current, phase angle, harmonics, interharmonics,
generation of fast transients ("Current Dips")

Intuitive User Interface
Modbus/Ethernet Open protocol, Labview drivers



Highlights



Efficiency and Flexibility



Save Energy, Power and Time



Full options and power in AC&DC



Smartgrids & Electrical Vehicles



High-Resolution and Dynamics

Applications

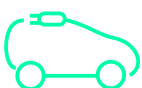

Electrical Vehicles and EVSE

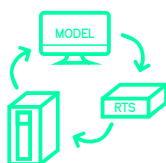

Power HiL



PV Inverter Emulation



Battery Testing and Emulation

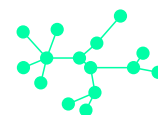

Smartgrids and ESS



Aeronautic
(+270V | 0 | -270V)

Bidirectional and Regenerative Hardware

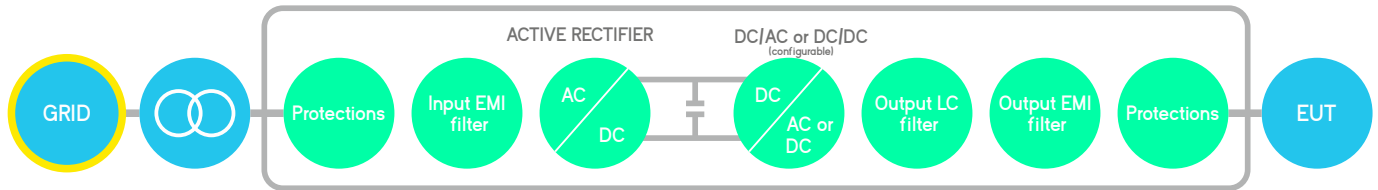

The hardware platform is based on a Back-to-Back power conversion topology, formed by two IGBT-based power stages. The grid side stage is an Active Rectifier which produces clean sinusoidal currents with very low harmonic distortion and power factor close to one.

The EUT side stage can be configured for AC voltage source or AC current source or DC output. In AC, voltage/current are controlled by using state of the art digital Proportional-Resonant controllers. In DC, the three independent buck-boost bidirectional legs enable the separated control of three different DC voltages or currents.

Block diagram

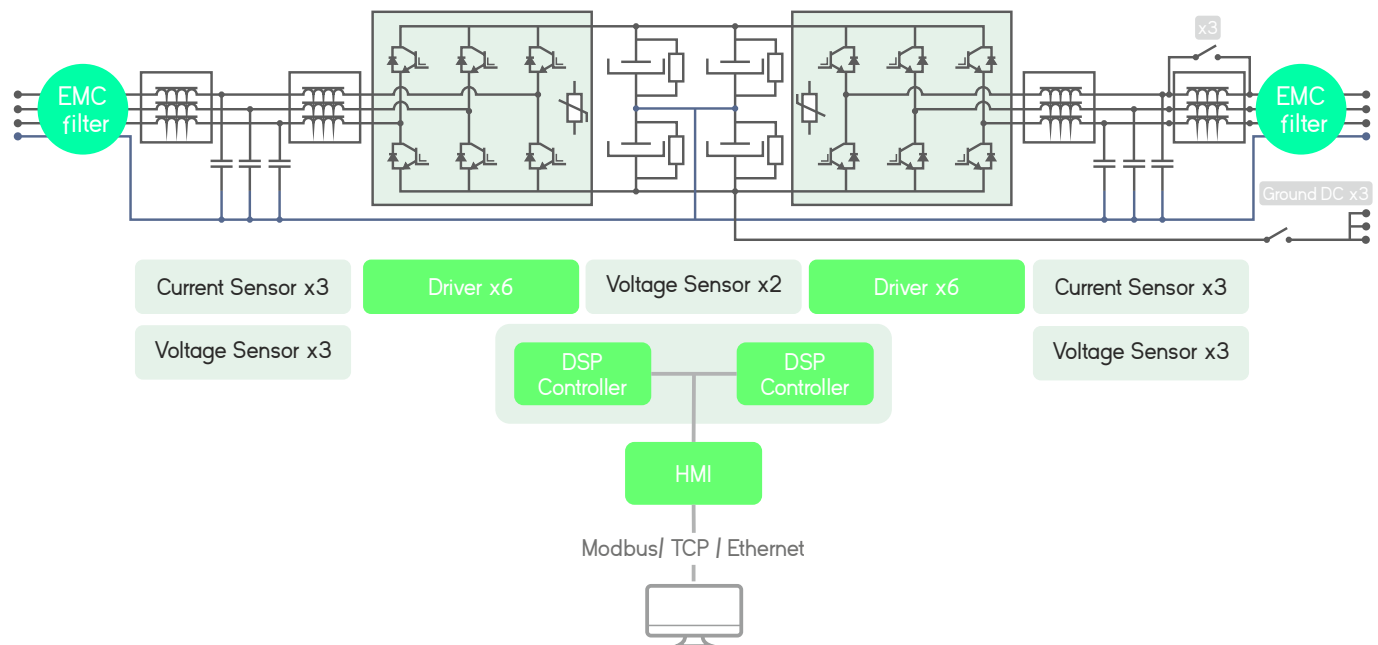

Local Interface

Analogue and Digital IO ports

The isolated digital and analogue inputs/outputs permit the connection of the unit to External Controllers and Power Hardware in the Loop systems (option).

4.3" Touchscreen

Allows the local parameterization and command of the device, configuration of the communications link, plots the main signals and enables the local datalogging.



Safety First

The units integrate a local Emergency Stop pushbutton and two signals (input + output) to be connected to the laboratory interlock system. Additionally, the digital outputs can be interfaced to safety tower lights.

Software Interface in EL+ modes

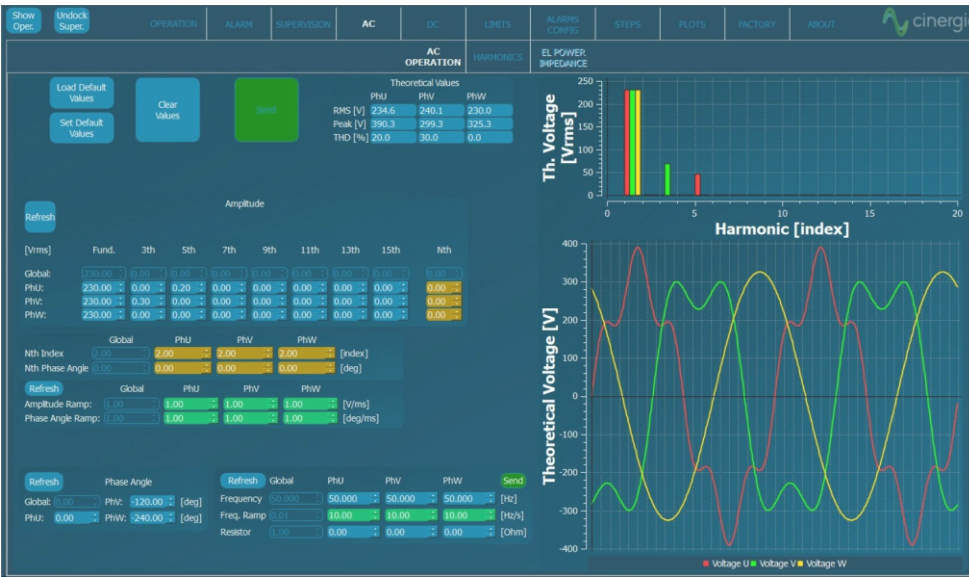

AC Operation

From this panel, the user can set all AC parameters. Each phase can be independently configured: RMS current magnitude, phase delay, harmonics content, free-frequency harmonic and transition ramps. A plot shows the expected real-time waveform, the FFT representation and the numeric data: RMS, peak, CF and THD.

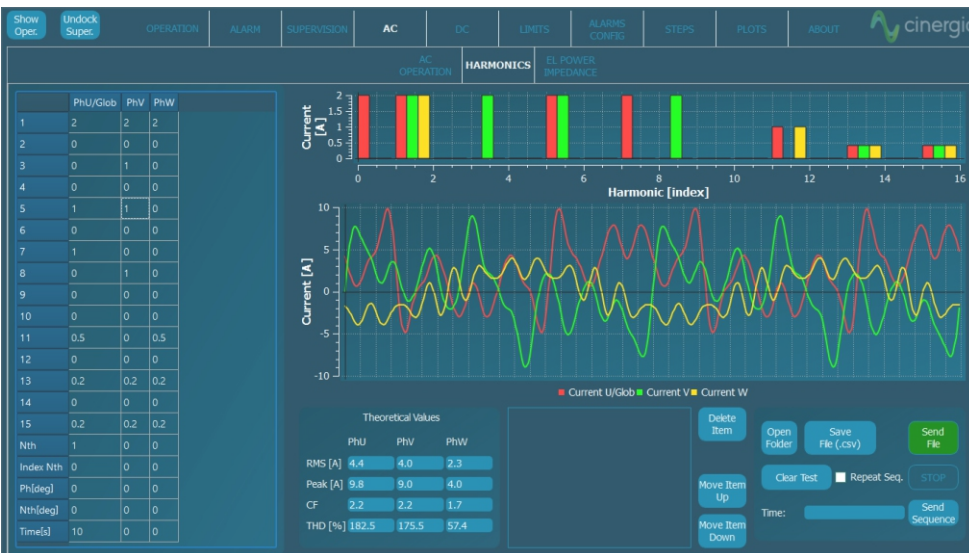

Harmonics

The device can control simultaneously the magnitude of the first 15 harmonics and one free harmonic per phase. The free one allows the generation of sub-harmonics, inter-harmonics and high frequency harmonics up to the 50th, setting both the magnitude and phase delay.



Power and Impedance Control

In Power mode, the active and reactive power of each phase is independently controlled. In Impedance mode, the device emulates an RLC load allowing to parameterize resistance, inductance and capacitance per phase making this device suitable for Anti-Islanding test of grid converters.

Advanced AC Software Applications

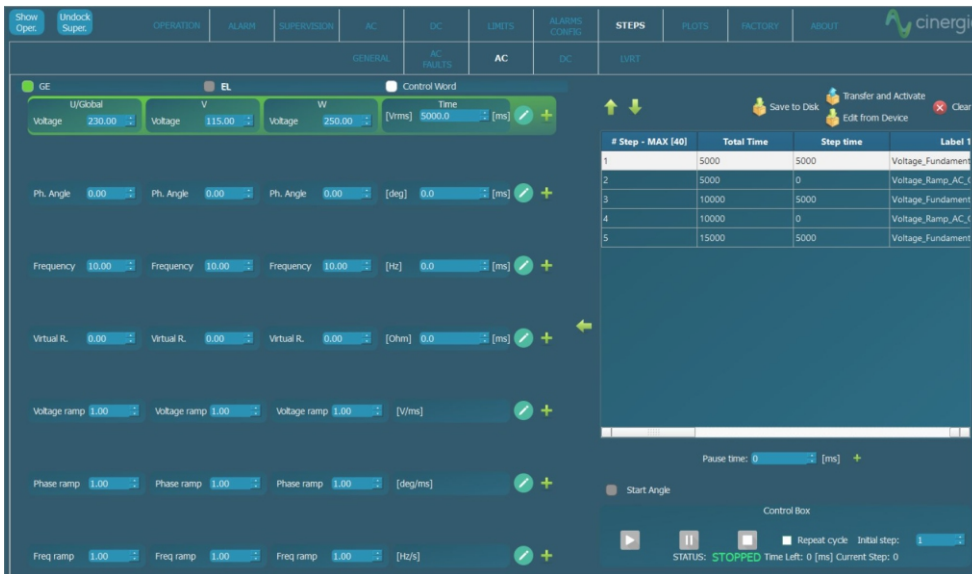

Steps Mode

One of the most remarkable novelties of the new software is the steps functionality. Step test files are saved and executed by the DSP allowing deterministic timing with a resolution of 66µs. The user gains access to all registers of the device to create complex test sequences which run directly in the converter without the need of an external computer.



Disturbance Generation

The steps mode includes predefined easy-to-use test panels. The AC faults panel is a powerful yet intuitive editor which allows generating and configuring flicker. Specific profiles can be saved in .csv files, modified, and reused by importing an existing one.



Lineal & Non-Lineal Emulation

The capacity to emulate linear and non-linear loads is one of the main features of the 4Q Electronic Load. Through our intuitive control software, the magnitude of harmonics can be set and different types of loads can be generated.

Software Interface in DC

The screenshot shows the 'DC UNIPOLAR' control panel. It features several sections for parameter configuration:

- Current:** Output U, V, W, and Global, each with Set Point and Actual Value fields.
- Power:** Output U, V, W, and Global, each with Set Point and Actual Value fields.
- Resistor:** Output U, V, W, and Global, each with Set Point and Actual Value fields.
- Voltage Source:** Output U, V, W, and Global, each with Set Point and Actual Value fields.
- Limits:** Min. Voltage, Max. Voltage, Min. Current, and Max. Current, each with a Limit Set Point field.

Buttons for 'Send Set Points', 'Refresh Set Points', 'Send Limits', and 'Refresh Limits' are visible on the right side.

DC Operation

This panel allows the user to access all DC setpoints and limits. Thanks to the unique Multichannel feature, each phase can have a different Operation Mode: voltage, current, power, resistance and advanced DC applications. Transition ramps, voltage and current limits can be modified. The limits for sink and source operation are different for safer testing, specially in battery applications.

The screenshot shows the 'DC SEQUENCE' control panel. It includes a sequence editor table and various control parameters:

	1	2	3	4	5	6	7	t
1	Voltage	Voltage	Voltage	100	10	10	10	1
2	Current	Resist...	Current	100	10	10	1	1
3	Power	Power	Current	100	20...	20...	10	1
4	Power	Voltage	Current	100	20...	10	10	1
5	Resist...	Voltage	Current	100	10	10	1	1
6	Voltage	Resist...	Current	100	10	10	1	1

Control parameters include Voltage SetPoint, Current SetPoint, Power SetPoint, and Resistor SetPoint for PHU, PHV, and PHW phases. A 'Step Time [ms]' field is set to 100.

Sequence

The User Interface Software integrates a Sequence Editor to create automatic test sequences, save them for future use and import them in .csv files.

A smart datalogger can be activated from the LCD of the unit to record automatically the resulting voltage and current measurements with a time resolution of 400 ms.

The screenshot shows the DC control panel with various status indicators and connection settings:

- Status:** Initialization, Ready, StandBy, Run, PreCharge, Alarm.
- Step Status:** STOPPED.
- Connection Method:** Modbus TCP.
- Server IP/port:** 127.0.0.1, 502.
- Modbus ID:** 1.
- Connection:** (Indicator)
- Lower Range Limit:** 192.168.55.153.
- Upper Range Limit:** 192.168.55.153.
- Serial Number:** (Indicator)
- Scan Timeout (ms):** 100.
- Grid side Reactive Power Set Point:** Q_abr_R [var]: 0.00, Q_abr_S [var]: 0.00, Q_abr_T [var]: 0.00.

Multichannel

Enabling the Separated Channel Control converts the device in three functionally independent DC Bidirectional Power Supplies, sharing the common negative rail. Each channel can have a different status (ON, OFF, Warning, Alarm), Operation Mode (see Range and Specifications table), Setpoint, Ramp and Limits.

Advanced DC Applications

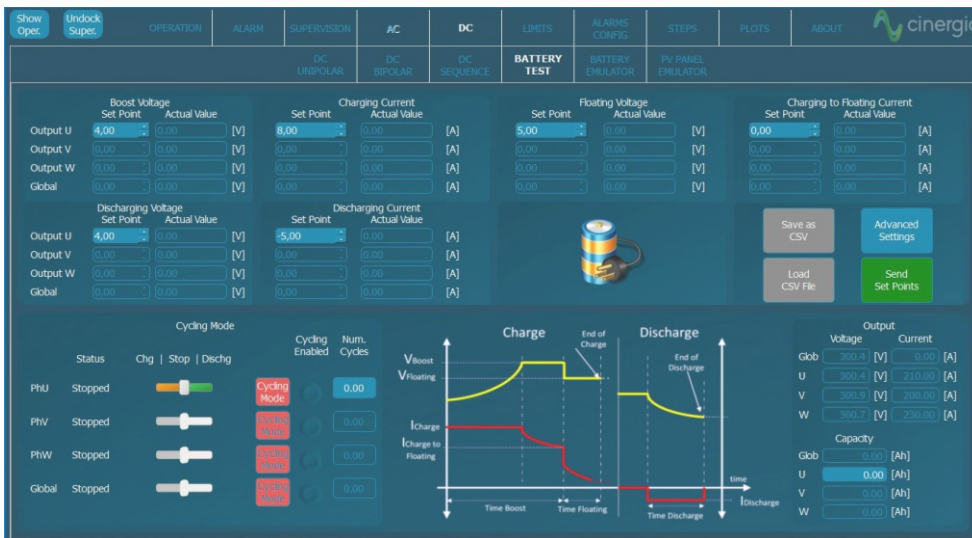

Battery Pack Testing

This functionality enables the user to precisely control the charge, discharge and cycling of a Battery. Basic parameters include the charge/discharge current, fast charge and floating voltages while Advanced parameters add Energy (Ah) and Time as transition conditions. Profiles for each Battery technology can be saved and imported in .CSV files.

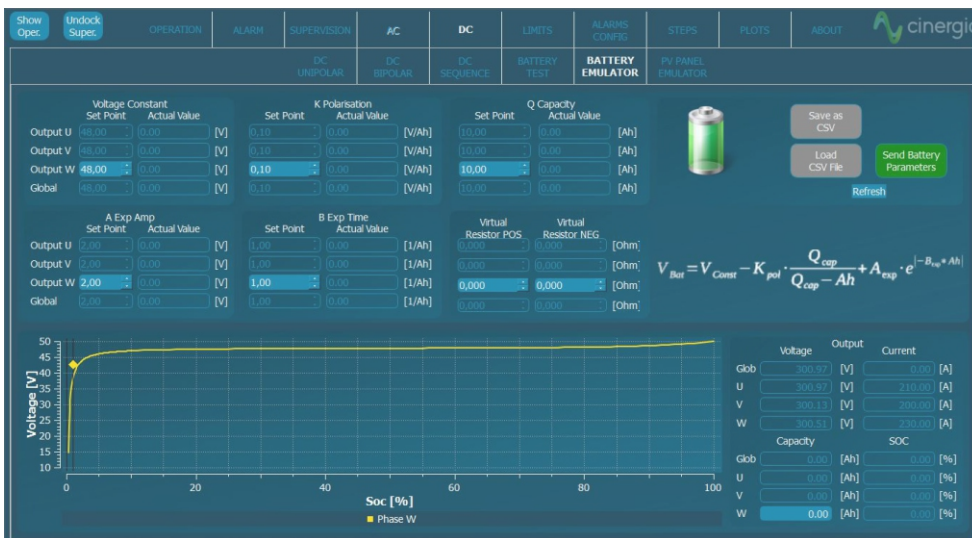

Battery Emulation

The B2C+ integrates a mathematical model to emulate the voltage behaviour of a real battery pack. The output voltage will change as a function of the SOC and Current. By configuring the provided parameters, the voltage profile can be adjusted to match different technologies: Lilon, NiMH, NiCd, Pb, Flux, etc...

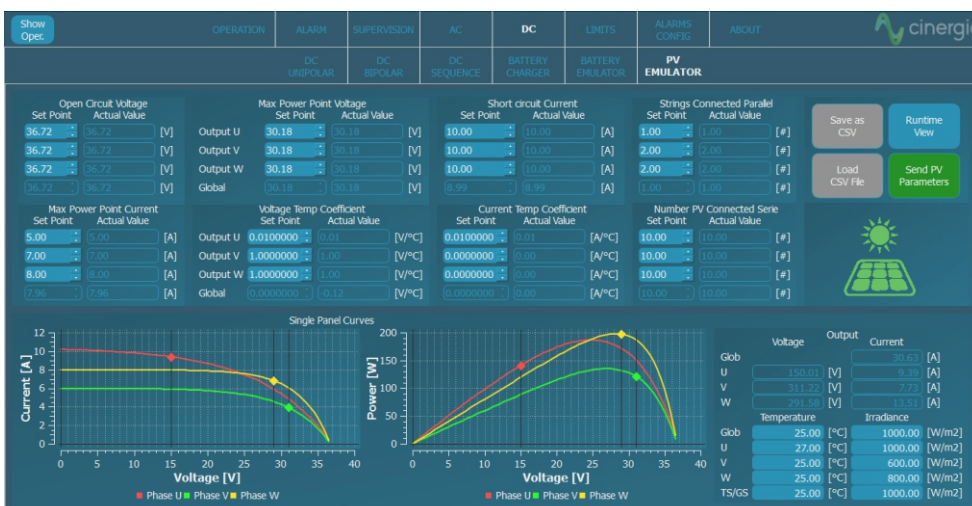

PV Panel Emulation

The PV Panel model is based on the single-diode equivalent circuit of a PV cell and the series-parallel connection of cells to form a panel. A Runtime functionality allows the simulation of a complete day by launching different irradiance and temperature setpoints from a .csv file, enabling the user burn-in and functional tests of PV Inverters.

EL+ vAC/DC Range & Specifications

Input side (GRID side)

AC Voltage
Rated: 3x400Vrms + Neutral + Earth
Range: +15% / -20%

Rated AC Current
Depends on model (see Wiring Manual)

Frequency
48-62Hz

Current Harmonic Distortion
THDi < 3% at rated power

Current Power factor
PF > 0.98 at rated power

Efficiency
≥ 89% (7.5 & 10), ≥ 91% (15 to 30), ≥ 92% (40 to 200)

Output side in DC (EUT side)

Terminals
Number: 6 (3 positive + 3 negative)

Configuration of Channels
Unipolar Independent: 2Q, independent setpoints per channel
Unipolar Parallel: 2Q, one global setpoint for all channels
Multichannel: 2Q, independent start/stop, operation mode and setpoints per channel (note: multichannel is an option for ≥ 80kVA)
Bipolar (4Q two independent setpoints)

Voltage Mode (CV)
Range: 2Q: 20⁽¹⁾ to 750V (800V with High Voltage option)
4Q: 0 to +350V / 0 to -350 (+ rail / 0 / - rail, Bipolar configuration)
Setpoint Resolution: 10mV
Effective Resolution⁽²⁾: < 0.05% of FS⁽³⁾
Setpoint Accuracy⁽⁴⁾: ± 0.1% of FS⁽³⁾
Transient Time⁽⁵⁾: < 1ms (10% to 90% at a step to Vrated)
Ripple⁽⁷⁾ (peak-peak): < 0.55% of FS⁽³⁾

Current Mode (CC)
Range: from 0 to ± 110% of Irated (see models table)
Setpoint Resolution: 10mA
Effective Resolution⁽²⁾: < 0.05% of FS⁽³⁾ (< 0.1% models 7.5 & 10)
Setpoint Accuracy⁽⁴⁾: ± 0.2% of FS⁽³⁾
Transient Time⁽⁵⁾: < 1ms (10% to 90% at a step to Irated)
Ripple⁽⁷⁾ (peak-peak): < 0.7% of FS⁽³⁾

Power Mode (CP)
Range: from 0 to ± 200%⁽⁶⁾ of Prated (see models table)
Derived current setpoint: Psetpoint / Vmeasured
Setpoint Resolution: 1W
Effective Resolution⁽²⁾: < 0.1% of FS⁽³⁾ (< 0.25% models 7.5 & 10)
Setpoint Accuracy⁽⁴⁾: ± 0.4% of FS⁽³⁾
Transient Time⁽⁵⁾: < 2.5ms (10% to 90% at a step to Prated)

Resistance Mode (CR)
Range: from 0.1 to 1000 Ohm
Derived current: Vmeasured / Rsetpoint
Setpoint Resolution: 0.01 Ohm
Setpoint Accuracy⁽⁴⁾: ± 0.2% of FS⁽³⁾
Transient Time⁽⁵⁾: < 2ms (10% to 90% at a step to Rrated)

Output side in AC (EUT side)

Terminals
Number: 4 (3 phases + 1 neutral)

Configuration of Channels
Independent: 4Q, independent setpoints per phase
Multichannel: 4Q, independent start/stop, alarm status and setpoints per phase (note: multichannel is an option for ≥ 80kVA)

Output side in EL-AC

Admissible Voltage

Connection: 1-phase or 3-phase star (consult us for 3-phase delta)

Maximum: $\pm 400V$ peak

Range: 10-100Hz

35^{III} to 277Vrms phase-neutral (295Vrms with HV option)

35^{III} to 480Vrms phase-phase (510Vrms with HV option)

> 100Hz: maximum rms voltage follows $V \cdot f < 46000$

Frequency: 10 to 400Hz

Current Mode (CC)

Range: from 0 to $\pm 200\%$ ⁽⁸⁾ of Irated (see models table)

Setpoint Resolution: 10mA_{rms}

Effective Resolution⁽²⁾: $< 0.05\%$ of FS⁽³⁾ ($< 0.1\%$ models 7.5 & 10)

Setpoint Accuracy⁽⁴⁾: $< \pm 0.2\%$ of FS⁽³⁾

Transient Time⁽⁵⁾: $< 1.5ms$ (10% to 90% at a step transient)

Ripple⁽⁷⁾ (peak-peak): $< 0.7\%$ of FS⁽³⁾ (with Low Ripple Inductor option)⁽¹⁾

Phase Angle (cos ϕ)

Range: -90 to 90° in Sink / Source

Resolution: 0.01°

Harmonics

Range: up to 50th

15 independent harmonics per phase:

14 fixed frequency multiple of f_0 : 2,3,4,5,6,7,8,9,10,11,12,13,14,15

1 free programmable frequency from 0.1 to 50 times f_0

Harmonics content: $V \cdot f < 46000$ (with current derating)

Setpoint Accuracy⁽⁴⁾: same as current accuracy

Small Signal Bandwidth: up to 5000Hz⁽⁹⁾

Transient Time⁽⁵⁾: $< 2ms$ (10% to 90% at a step change)

Power Mode (CP / CS)

Range: from 0 to $\pm 200\%$ ⁽⁸⁾ of Prated (see models table)

Derived current setpoint: calculated from |S| and $\Phi(S)$

Setpoint Resolution: 1W, 1VA

Effective Resolution⁽²⁾: $< 0.1\%$ of FS⁽³⁾ ($< 0.25\%$ models 7.5 & 10)

Setpoint Accuracy⁽⁴⁾: $\pm 0.4\%$ of FS⁽³⁾

Transient Time⁽⁵⁾: $< 2.5ms$ (10% to 90% at a step to Prated)

Impedance Mode (CZ)

Range: from 0.8 to 1000 Ohm, 0.1 to 2000mH, 0 to 3.7mF

Derived current/phase setpoint: calculated from |Z| and $\Phi(Z)$

Setpoint Resolution: 0.01 Ohm/mH/mF

Setpoint Accuracy⁽⁴⁾: see current accuracy

Transient Time⁽⁵⁾: $< 2.5ms$ (10% to 90% at a step to Rated)

Operation Modes

DC

Programmable Voltage (CV)

Programmable Current (CC)

Programmable Power (CP)

Programmable Resistance (CR)

Power Amplifier (HiL)

Steps

Optional Battery Testing (BTest) (charge/discharge/cycling)

Optional Battery Emulation (Bemu)

Optional PV Panel Emulation (PVEmu)

AC

Programmable Current (CC)

Programmable Power (CP / CS)

Programmable Impedance (CZ)

Power Amplifier (HiL)

Steps

Overload/ Overcurrent

Admissible DC overcurrent is: 110% of rated value during 1 minute

Admissible AC overcurrent: 125% of rated value during 10 minutes,

150% during 1 minute, 200% during 2 seconds

Admissible overloads: 125% of rated value during 10 minutes,

150% during 1 minute, 200% during 2 seconds

User Interface

Local Control (4.3" Touchscreen panel)
Isolated Digital port: 6 inputs, 4 outputs
Isolated Analogue port: 6 inputs (rms setpoints or power amplifier)
6 outputs (rms readback or real-time readback)
Interlock port: 1 NC Input, 1 NO Output
Emergency Stop pushbutton
Remote Control Port
LAN Ethernet with Open Modbus-TCP protocol
RS485 (option), CAN and RS232 (using external gateway)
Software
Graphical User Interface for Windows 7/10
LabView drivers and open Labview interface example

Protections

Overvoltage (peak, rms), Overcurrent (peak, rms), Overload
Shortcircuit, Emergency Stop, Watchdog, Heart Beat, Output
Contactor, Wrong Configuration
Alarms and Limits are user configurable and can be saved in a
password protected EEPROM

Mesurements⁽⁶⁾

Grid Voltage (rms), Current (rms), Power (P,Q) and Frequency
Output Voltage (rms, avg), Current (rms, avg), Power (P,Q) and
Frequency
Heatsink Temperatures (x2) and DC Link Voltage
Datalogging available through FTP connection

Ambient

Operating temperature⁽⁸⁾: 5-40°C
Relative Humidity: up to 95%, non-condensing
Cooling: Forced air
Acoustic noise at 1m: < 52dB(A) (7.5 to 60), < 65dB(A) (80 to 120), < 70dB(A) (160 and 200)

Standards

CE Marking
Operation and Safety: EN-50178, EN-62040-1
EMC: EN-62040-2
RoHS

All specifications are subject to change without notice.

Save Energy
Save Power
Save Time

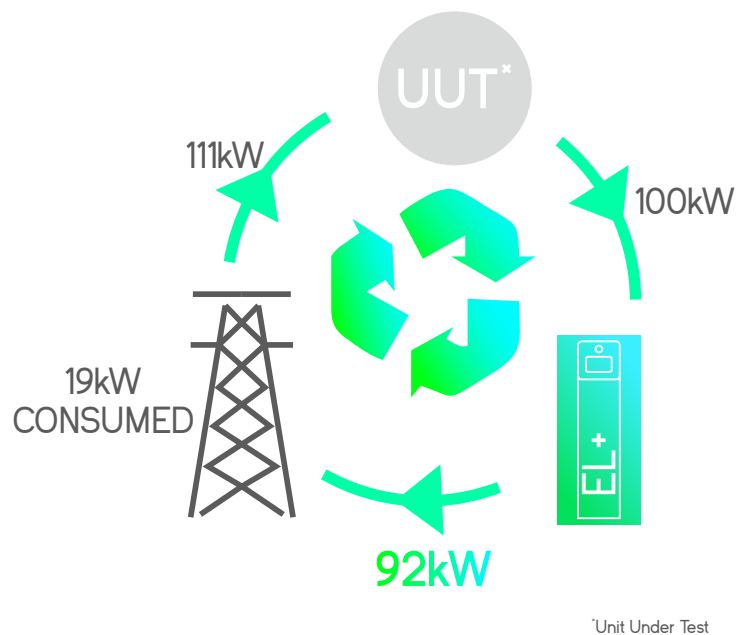

All specifications are subject to change without notice.

(1) Minimum voltage setpoint is 0V in DC. The recommended minimum setpoint for long-term use is 20Vrms in AC and 20V in DC.

(2) Effective resolution measured with a 400ms window

(3) FS Range of voltage is 800V (with High Voltage option)

FS Range of current is 2| 110% to I rated (see models table)

FS Range of power is 2| 200% to Prated (see models table)

(4) Accuracies are valid for settings above 10% of FS

(5) Measured with the rated resistive load and high-dynamics controllers configuration

(6) Accuracy of measurements is $\pm 0.1\%$ of FS for rms voltage, $\pm 0.2\%$ of FS for rms current,

$\pm 0.4\%$ of FS for active power (valid only above 10% of FS)

(7) Consult us for lower voltage/current ripple requirements

(8) Rated power figures are given at 20°C

(9) The maximum output voltage depends on frequency following $V_f < 46000$

Models

EL+ vAC/DC Full

Reference		AC Power Rated ⁽⁹⁾	DC Power Rated ⁽⁹⁾	AC Current Rated ⁽⁹⁾ RMS Per phase / Parallel	DC Current Rated ⁽⁹⁾ RMS Per phase / Parallel	Weight (kg)	Dimensions DxWxH (mm)
EL+7.5	vAC/DC	7.5kW	7.5kW	11A / 33A	±10A / ±30A	155 kg	770x450x1100 mm
EL+10	vAC/DC	10kW	10kW	15A / 45A	±15A / ±45A	155 kg	770x450x1100 mm
EL+15	vAC/DC	15kW	15kW	22A / 66A	±20A / ±60A	155 kg	770x450x1100 mm
EL+20	vAC/DC	20kW	20kW	29A / 87A	±25A / ±75A	155 kg	770x450x1100 mm
EL+30	vAC/DC	27kW	27kW	40A / 120A	±30A / ±90A	155 kg	770x450x1100 mm
EL+40	vAC/DC	40kW	40kW	58A / 174A	±40A / ±120A	190kg	770x450x1100 mm
EL+50	vAC/DC	50kW	50kW	73A / 219A	±50A / ±150A	190kg	770x450x1100 mm
EL+60	vAC/DC	54kW	54kW	80A / 240A	±57A / ±171A	190kg	770x450x1100 mm
EL+80	vAC/DC	80kW	80kW	116A / 348A	±105A / ±315A	270kg	880x875x1320 mm
EL+100	vAC/DC	100kW	100kW	145A / 435A	±130A / ±390A	295kg	880x875x1320 mm
EL+120	vAC/DC	108kW	108kW	157A / 471A	±130A / ±390A	295kg	880x875x1320 mm
EL+160	vAC/DC	145kW	145kW	211A / 633A	±155A / ±465A	545kg	850x900x2000 mm
EL+200	vAC/DC	160kW	160kW	232A / 696A	±185A / ±555A	555kg	850x900x2000 mm

All specifications are subject to change without notice.

Galvanic Isolation (optional)

	Circuit Breaker Recommended	Weight (kg)	Dimensions DxWxH (mm)
IT 7.5i	Type C - 25A	145 kg	Inside the cabinet
IT 10i	Type C - 25A	145 kg	Inside the cabinet
IT 15i	Type C - 32A	145 kg	Inside the cabinet
IT 20i	Type C - 40A	145 kg	Inside the cabinet
IT 30i	Type C - 50A	195 kg	Inside the cabinet
IT 30e	Type D - 80A	174 kg	595x415x708 mm
IT 40e	Type D - 100A	217 kg	789x490x865 mm
IT 50e	Type D - 125A	280 kg	789x490x865 mm
IT 60e	Type D - 160A	381 kg	789x490x865 mm
IT 80e	Type D - 200A	435 kg	964x684x1252 mm
IT 100e	Type D - 250A	458 kg	964x684x1252 mm
IT 120e	Type D - 315A	514 kg	964x684x1252 mm
IT 160e	Type D - 400A	612 kg	964x684x1252 mm
IT 200e	Type D - 500A	753 kg	1192x744x1430 mm

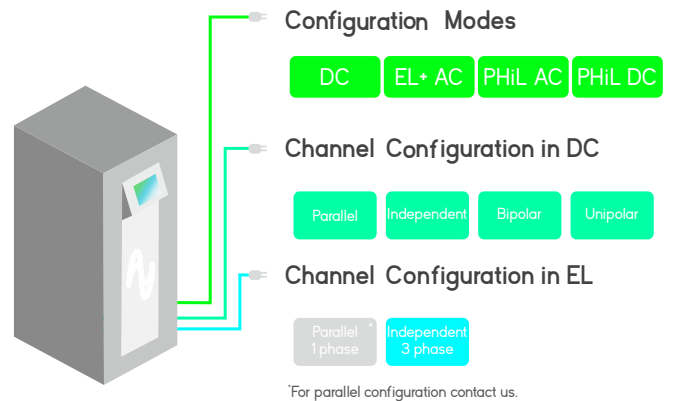

Options

Choose your options

- Galvanic Isolation
- Multichannel mode: allows different operation mode, start/stop/reset per channel (included in all models from 7.5 to 60, both included)
- 30kHz Switching Frequency: only available for models 15 (derated to 7.5kW), 20 (derated to 7.5kW) and 30 (derated to 10kW)
- Isolation monitor (advised for IT systems)
- Low current ripple inductance (included in all models ≤54kW, optional for models ≥80kW)
- High Frequency 360 - 900 Hz
- Anti-islanding monitor (only advised in net injection to the grid and following local regulations)
- High Voltage (HV): voltage up to 295Vrms phase-neutral in AC up to 800V in DC.
- RS485
- Battery Emulation,
- Battery Test
- PV Panel Emulation

CINERGIA, Regenerative Power Electronics Solutions

- Grid Emulators AC, DC, AC/DC
- Electronic Loads, AC, DC, AC/DC, HF (360-900Hz)
- Bidirectional DC, Battery Emulators, PV Panel Emulators

Pintor Roig i Soler, 10
08916, Badalona, BARCELONA
www.cinergia.coop
cinergia@cinergia.coop