

## Regenerative AC Electronic Load

EL+ vAC is a 4Q programmable AC Current Source designed to emulate the electrical behaviour of passive and active devices connected to the grid. This cost-effective solution is specially suitable for testing AC sources, UPS and EV Charging Infrastructure. Its Regenerative Hardware allows a reduction in the total power and energy needed for the test.

### Key features

Bidirectional and Regenerative  
Clean grid current: THDi < 3% and PF > 0.98

13 models from 7.5kW to 160kW  
Parallelization of units to increase the power

Emulation of grid-connected devices:  
Loads absorbing energy from grid.  
Generators injecting energy to the grid.  
Programmable Active/Reactive consumption  
Non-linear currents up to CF of 3

Independent phase configuration of:  
rms current, phase angle, harmonics, interharmonics,  
generation of fast transients ("Current Dips")

Intuitive User Interface  
Modbus/Ethernet Open protocol, Labview drivers



### Highlights



Efficiency and Flexibility



Save Energy, Power and Time

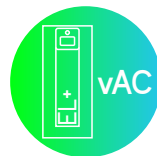

AC only



Smartgrids & Electrical Vehicles



High-Resolution and Dynamics

### Applications

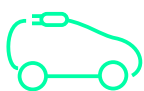

Electrical Vehicles and EVSE



Applications for Industry and Education

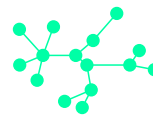

Smartgrids and ESS



Avionics

# Bidirectional and Regenerative Hardware

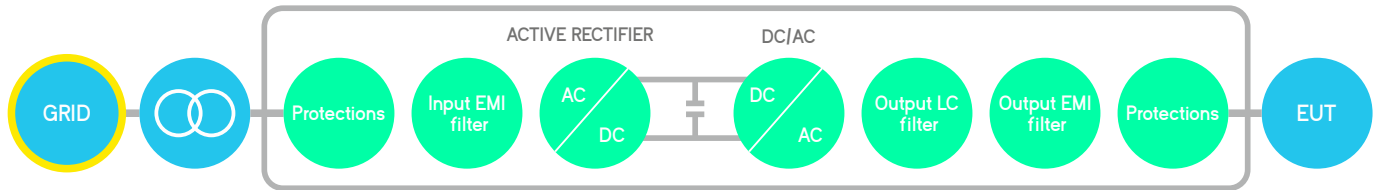

The hardware platform is based on a Back-to-Back power conversion topology, formed by two IGBT-based power stages. The grid side stage is an Active Rectifier which produces clean sinusoidal currents with very low harmonic distortion and power factor close to one.

The EUT side stage can be configured for AC voltage source or AC current source or DC output. In AC, voltage/current are controlled by using state of the art digital Proportional-Resonant controllers. In DC, the three independent buck-boost bidirectional legs enable the separated control of three different DC voltages or currents.

## Block diagram

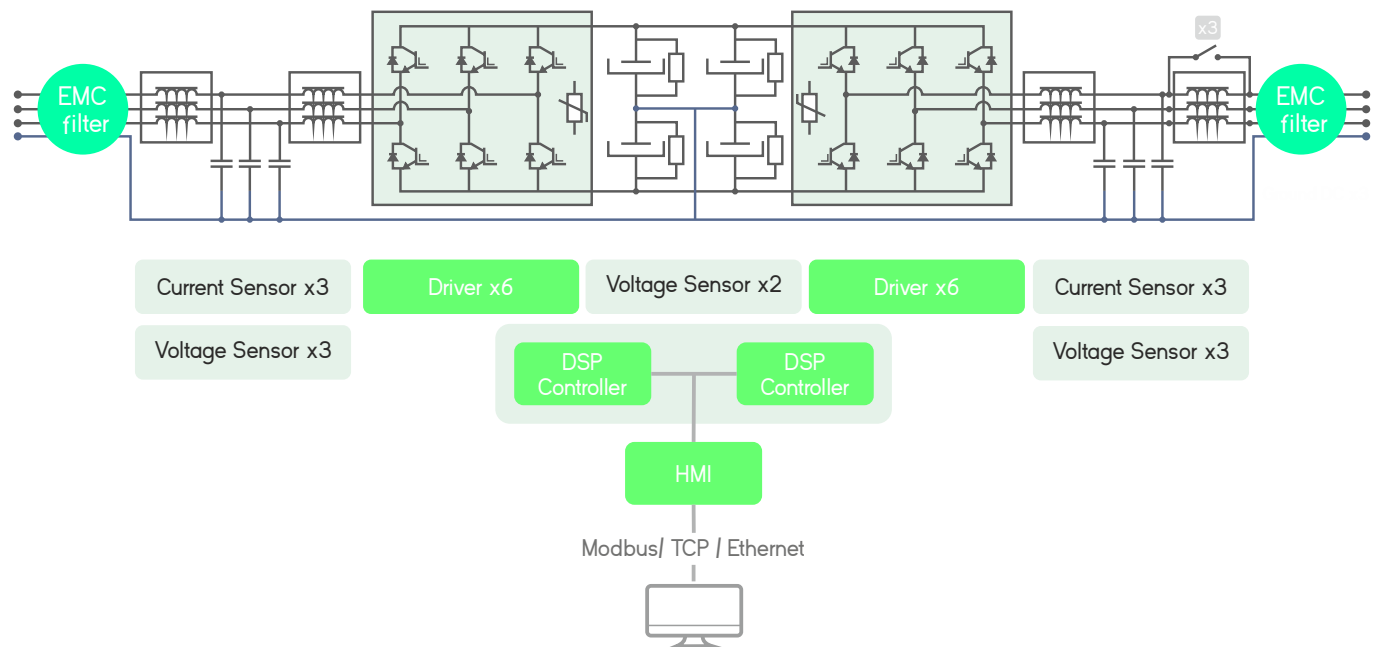

## Local Interface

### Analogue and Digital IO ports

The isolated digital and analogue inputs/outputs permit the connection of the unit to External Controllers and Power Hardware in the Loop systems (option).

### 4.3" Touchscreen

Allows the local parameterization and command of the device, configuration of the communications link, plots the main signals and enables the local datalogging.



### Safety First

The units integrate a local Emergency Stop pushbutton and two signals (input + output) to be connected to the laboratory interlock system. Additionally, the digital outputs can be interfaced to safety tower lights.

# Software Interface in EL+ modes

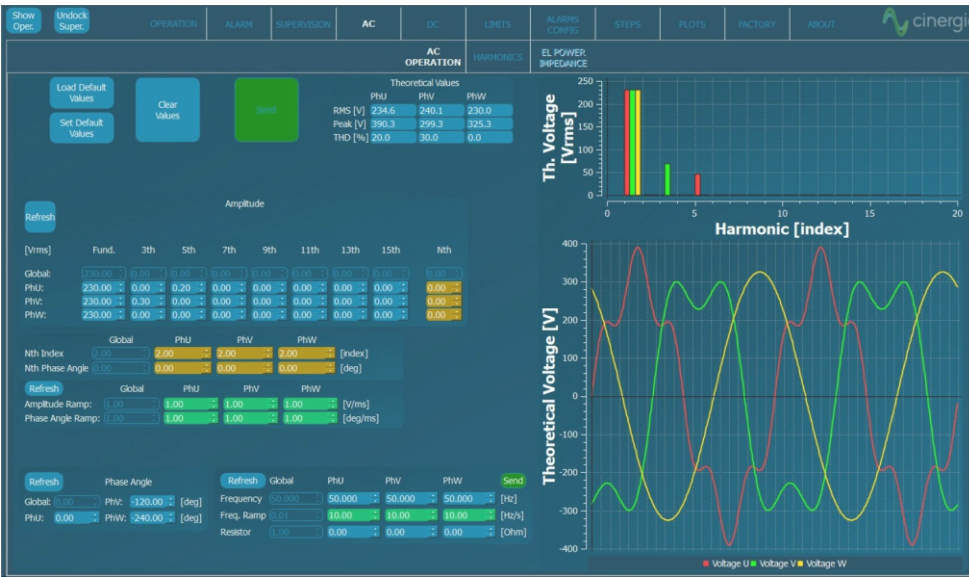

## AC Operation

From this panel, the user can set all AC parameters. Each phase can be independently configured: RMS current magnitude, phase delay, harmonics content, free-frequency harmonic and transition ramps. A plot shows the expected real-time waveform, the FFT representation and the numeric data: RMS, peak, CF and THD.

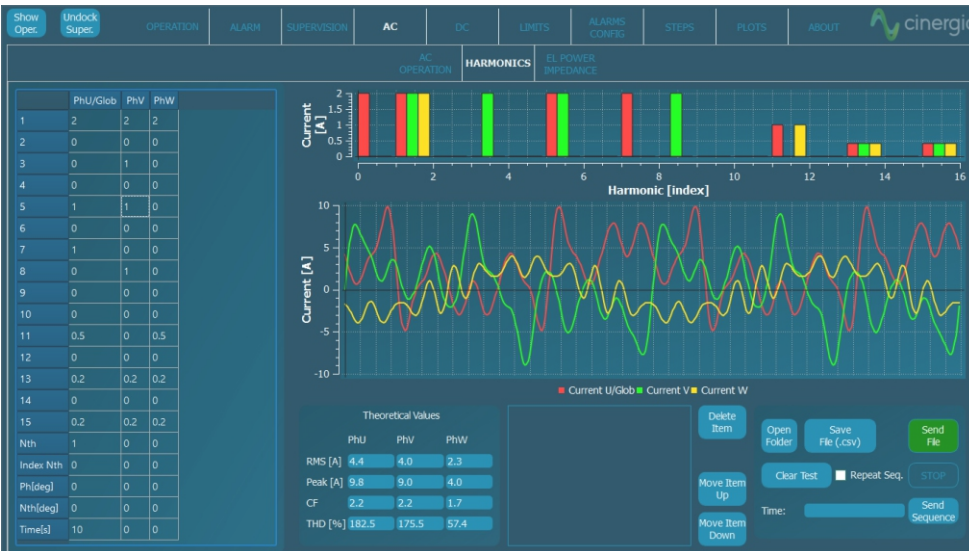

## Harmonics

The device can control simultaneously the magnitude of the first 15 harmonics and one free harmonic per phase. The free one allows the generation of sub-harmonics, inter-harmonics and high frequency harmonics up to the 50th, setting both the magnitude and phase delay.



## Power and Impedance Control

In Power mode, the active and reactive power of each phase is independently controlled. In Impedance mode, the device emulates an RLC load allowing to parameterize resistance, inductance and capacitance per phase making this device suitable for Anti-Islanding test of grid converters.



# Advanced AC Software Applications

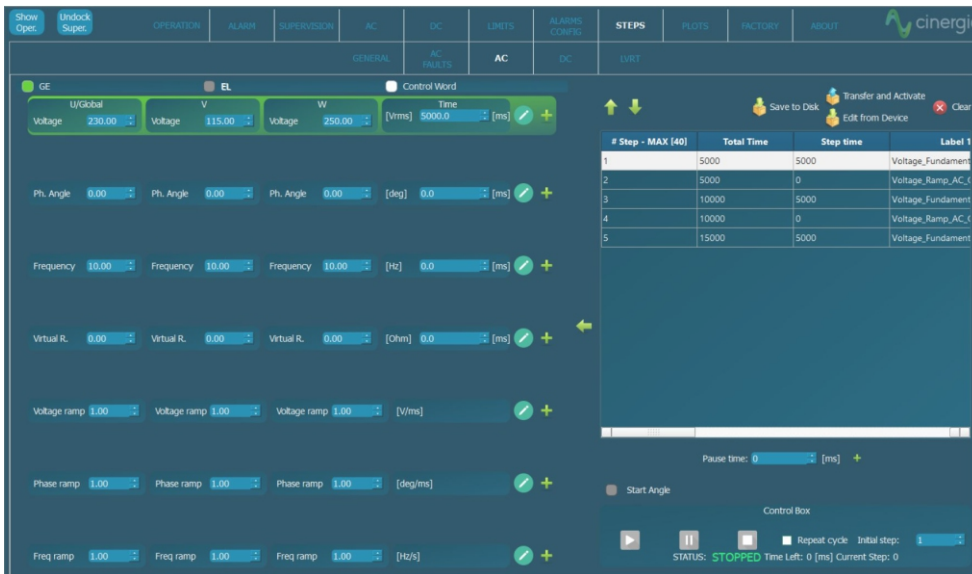

## Steps Mode

One of the most remarkable novelties of the new software is the steps functionality. Step test files are saved and executed by the DSP allowing deterministic timing with a resolution of 66µs. The user gains access to all registers of the device to create complex test sequences which run directly in the converter without the need of an external computer.

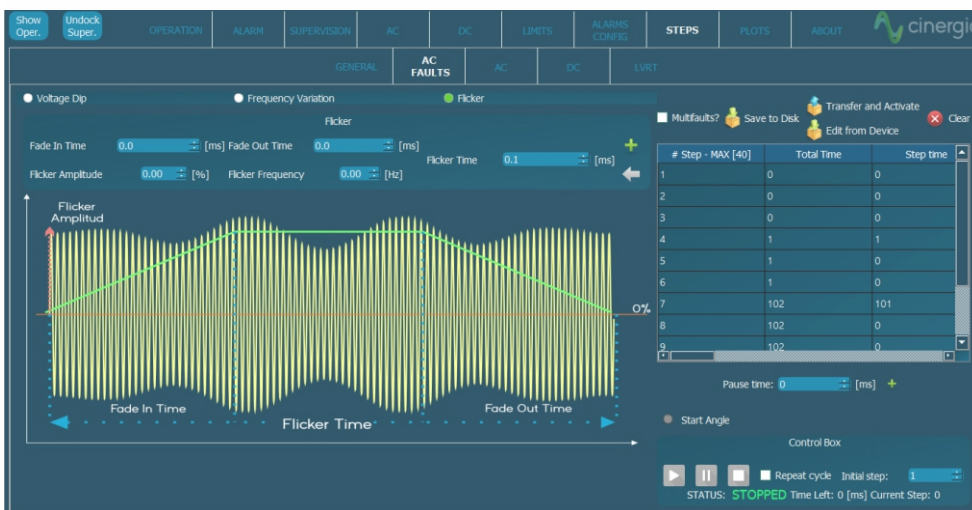

## Disturbance Generation

The steps mode includes predefined easy-to-use test panels. The AC faults panel is a powerful yet intuitive editor which allows generating and configuring flicker. Specific profiles can be saved in .csv files, modified, and reused by importing an existing one.

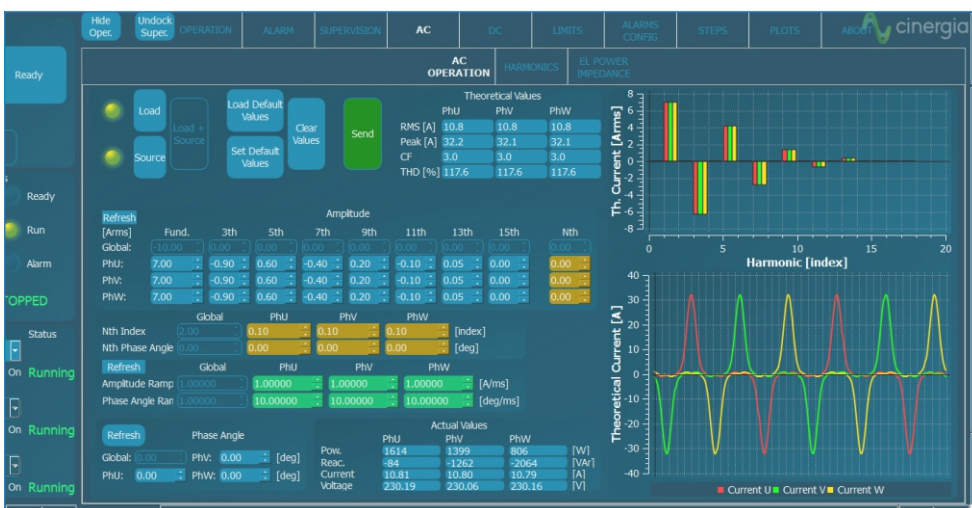

## Lineal & Non-Lineal Emulation

The capacity to emulate linear and non-linear loads is one of the main features of the 4Q Electronic Load. Through our intuitive control software, the magnitude of harmonics can be set and different types of loads can be generated.

# EL+ vAC Range & Specifications

---

## Input side (GRID side)

**AC Voltage**  
Rated: 3x400Vrms + Neutral + Earth  
Range: +15% / -20%

**Rated AC Current**  
Depends on model (see Wiring Manual)

**Frequency**  
48-62Hz

**Current Harmonic Distortion**  
THDi < 3% at rated power

**Current Power factor**  
PF > 0.98 at rated power

**Efficiency**  
≥ 89% (7.5 & 10), ≥ 91% (15 to 30), ≥ 92% (40 to 200)

---

## Output side in AC (EUT side)

**Terminals**  
Number: 4 (3 phases + 1 neutral)

**Configuration of Channels**  
Independent: 4Q, independent setpoints per phase  
Multichannel: 4Q, independent start/stop, alarm status and setpoints per phase (note: multichannel is an option for ≥ 80kVA)

---

## Output side in EL-AC

**Admissible Voltage**  
Connection: 1-phase or 3-phase star (consult us for 3-phase delta)  
Maximum: ± 400V peak  
Range: 10-100Hz  
35<sup>(1)</sup> to 277Vrms phase-neutral (295Vrms with HV option)  
35<sup>(1)</sup> to 480Vrms phase-phase (510Vrms with HV option)  
> 100Hz: maximum rms voltage follows  $V \cdot f < 46000$   
Frequency: 10 to 400Hz

**Current Mode (CC)**  
Range: from 0 to ± 200%<sup>(8)</sup> of Irated (see models table)  
Setpoint Resolution: 10mArms  
Effective Resolution<sup>(2)</sup>: < 0.05% of FS<sup>(3)</sup> (< 0.1% models 7.5 & 10)  
Setpoint Accuracy<sup>(4)</sup>: < ± 0.2% of FS<sup>(3)</sup>  
Transient Time<sup>(5)</sup>: < 1.5ms (10% to 90% at a step transient)  
Ripple<sup>(7)</sup> (peak-peak): < 0.7% of FS<sup>(3)</sup> (with Low Ripple Inductor option)

**Phase Angle (cos φ)**  
Range: -90 to 90° in Sink / Source  
Resolution: 0.01°

**Harmonics**  
Range: up to 50th  
15 independent harmonics per phase:  
14 fixed frequency multiple of  $f_0$ : 2,3,4,5,6,7,8,9,10,11,12,13,14,15  
1 free programmable frequency from 0.1 to 50 times  $f_0$   
Harmonics content:  $V \cdot f < 46000$  (with current derating)  
Setpoint Accuracy<sup>(4)</sup>: same as current accuracy  
Small Signal Bandwidth: up to 5000Hz<sup>(9)</sup>  
Transient Time<sup>(5)</sup>: < 2ms (10% to 90% at a step change)

**Power Mode (CP / CS)**  
Range: from 0 to ± 200%<sup>(8)</sup> of Prated (see models table)  
Derived current setpoint: calculated from |S| and Φ(S)  
Setpoint Resolution: 1W, 1VA  
Effective Resolution<sup>(2)</sup>: < 0.1% of FS<sup>(3)</sup> (< 0.25% models 7.5 & 10)  
Setpoint Accuracy<sup>(4)</sup>: ± 0.4% of FS<sup>(3)</sup>  
Transient Time<sup>(5)</sup>: < 2.5ms (10% to 90% at a step to Prated)

**Impedance Mode (CZ)**  
Range: from 0.8 to 1000 Ohm, 0.1 to 2000mH, 0 to 3.7mF  
Derived current/phase setpoint: calculated from |Z| and Φ(Z)  
Setpoint Resolution: 0.01 Ohm/mH/mF  
Setpoint Accuracy<sup>(4)</sup>: see current accuracy  
Transient Time<sup>(5)</sup>: < 2.5ms (10% to 90% at a step to Rrated)

---

---

## Operation Modes

AC  
Programmable Current (CC)  
Programmable Power (CP / CS)  
Programmable Impedance (CZ)  
Steps

---

## Overload/Overcurrent

Admissible AC overcurrent: 125% of rated value during 10 minutes,  
150% during 1 minute, 200% during 2 seconds  
Admissible overloads: 125% of rated value during 10 minutes,  
150% during 1 minute, 200% during 2 seconds

---

## User Interface

**Local Control (4.3" Touchscreen panel)**  
Isolated Digital port: 6 inputs, 4 outputs  
Isolated Analogue port: 6 inputs (rms setpoints or power amplifier)  
6 outputs (rms readback or real-time readback)  
Interlock port: 1 NC Input, 1 NO Output  
Emergency Stop pushbutton  
**Remote Control Port**  
LAN Ethernet with Open Modbus-TCP protocol  
RS485 (option), CAN and RS232 (using external gateway)  
**Software**  
Graphical User Interface for Windows 7/10  
LabView drivers and open Labview interface example

---

## Protections

Overvoltage (peak, rms), Overcurrent (peak, rms), Overload  
Shortcircuit, Emergency Stop, Watchdog, Heart Beat, Output  
Contactor, Wrong Configuration  
Alarms and Limits are user configurable and can be saved in a  
password protected EEPROM

---

## Mesurements<sup>(6)</sup>

Grid Voltage (rms), Current (rms), Power (P,Q) and Frequency  
Output Voltage (rms, avg), Current (rms, avg), Power (P,Q) and  
Frequency  
Heatsink Temperatures (x2) and DC Link Voltage  
Datalogging available through FTP connection

---

## Ambient

Operating temperature<sup>(8)</sup>: 5-40°C  
Relative Humidity: up to 95%, non-condensing  
Cooling: Forced air  
Acoustic noise at 1m: < 52dB(A) (7.5 to 60), < 65dB(A) (80 to 120), < 70dB(A) (160 and 200)

---

## Standards

CE Marking  
Operation and Safety: EN-50178, EN-62040-1  
EMC: EN-62040-2  
RoHS

---

All specifications are subject to change without notice.

All specifications are subject to change without notice.

(1) Minimum voltage setpoint is 0V in DC. The recommended minimum setpoint for long-term use is 20Vrms in AC and 20V in DC.

(2) Effective resolution measured with a 400ms window

(3) FS Range of voltage is 800V (with High Voltage option)

FS Range of current is 2|110% to Irated (see models table)

FS Range of power is 2|200% to Prated (see models table)

(4) Accuracies are valid for settings above 10% of FS

(5) Measured with the rated resistive load and high-dynamics controllers configuration

(6) Accuracy of measurements is ±0.1% of FS for rms voltage, ±0.2% of FS for rms current, ±0.4% of FS for active power (valid only above 10% of FS)

(7) Consult us for lower voltage/current ripple requirements

(8) Rated power figures are given at 20°C

(9) The maximum output voltage depends on frequency following  $V_f < 46000$

# Save Energy Save Power Save Time

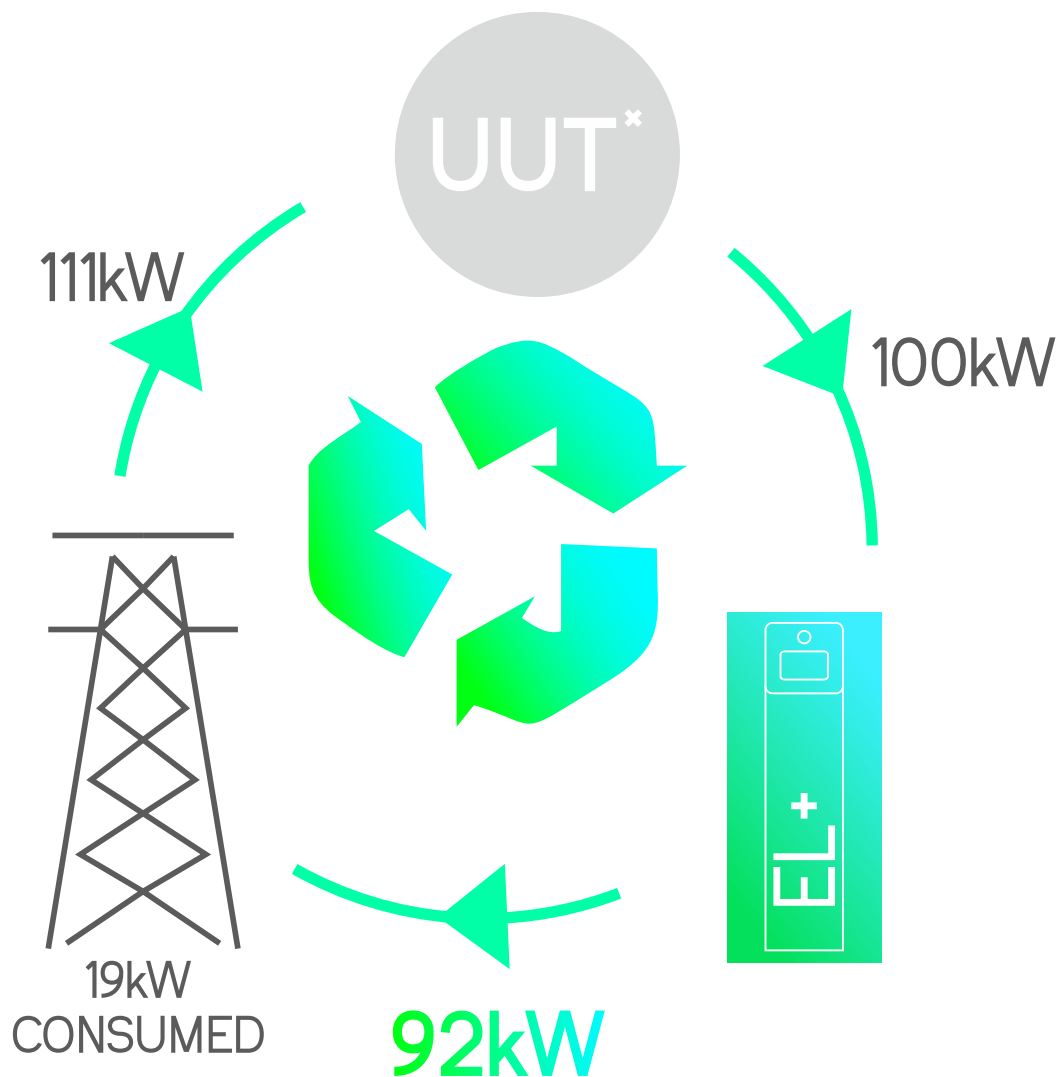

\*Unit Under Test

# Models

## EL+ vAC

Reference	AC Power Rated <sup>(9)</sup>	AC Current Rated <sup>(9)</sup> RMS Per phase / Parallel	Weight (kg)	Dimensions DxWxH (mm)
EL+7.5 vAC	7.5kW	11A / 33A	155 kg	770x450x1100 mm
EL+10 vAC	10kW	15A / 45A	155 kg	770x450x1100 mm
EL+15 vAC	15kW	22A / 66A	155 kg	770x450x1100 mm
EL+20 vAC	20kW	29A / 87A	155 kg	770x450x1100 mm
EL+30 vAC	27kW	40A / 120A	155 kg	770x450x1100 mm
EL+40 vAC	40kW	58A / 174A	190kg	770x450x1100 mm
EL+50 vAC	50kW	73A / 219A	190kg	770x450x1100 mm
EL+60 vAC	54kW	80A / 240A	190kg	770x450x1100 mm
EL+80 vAC	80kW	116A / 348A	270kg	880x875x1320 mm
EL+100 vAC	100kW	145A / 435A	295kg	880x875x1320 mm
EL+120 vAC	108kW	157A / 471A	295kg	880x875x1320 mm
EL+160 vAC	145kW	211A / 633A	545kg	850x900x2000 mm
EL+200 vAC	160kW	232A / 696A	555kg	850x900x2000 mm

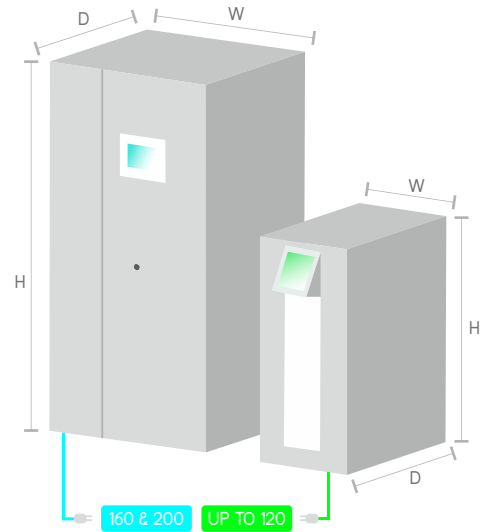

All specifications are subject to change without notice.

## Galvanic Isolation (optional)

	Circuit Breaker Recommended	Weight (kg)	Dimensions DxWxH (mm)
IT 7.5i	Type C - 25A	145 kg	Inside the cabinet
IT 10i	Type C - 25A	145 kg	Inside the cabinet
IT 15i	Type C - 32A	145 kg	Inside the cabinet
IT 20i	Type C - 40A	145 kg	Inside the cabinet
IT 30i	Type C - 50A	195 kg	Inside the cabinet
IT 30e	Type D - 80A	174 kg	595x415x708 mm
IT 40e	Type D - 100A	217 kg	789x490x865 mm
IT 50e	Type D - 125A	280 kg	789x490x865 mm
IT 60e	Type D - 160A	381 kg	789x490x865 mm
IT 80e	Type D - 200A	435 kg	964x684x1252 mm
IT 100e	Type D - 250A	458 kg	964x684x1252 mm
IT 120e	Type D - 315A	514 kg	964x684x1252 mm
IT 160e	Type D - 400A	612 kg	964x684x1252 mm
IT 200e	Type D - 500A	753 kg	1192x744x1430 mm

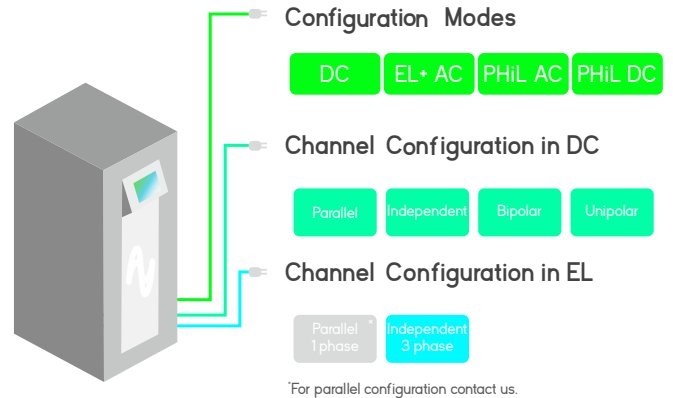

## Options

Choose your options

- Galvanic Isolation
- Multichannel mode: allows different operation mode, start/stop/reset per channel (included in all models from 7.5 to 60, both included)
- 30kHz Switching Frequency: only available for models 15 (derated to 7.5kW), 20 (derated to 7.5kW) and 30 (derated to 10kW)
- Isolation monitor (advised for IT systems)
- Low current ripple inductance (included in all models ≤54kW, optional for models ≥80kW)
- High Frequency 360 - 900 Hz
- Anti-islanding monitor (only advised in net injection to the grid and following local regulations)
- High Voltage (HV): voltage up to 295Vrms phase-neutral in AC up to 800V in DC.
- RS485

## CINERGIA, Regenerative Power Electronics Solutions

- Grid Emulators AC, DC, AC/DC
- Electronic Loads, AC, DC, AC/DC, HF (360-900Hz)
- Bidirectional DC, Battery Emulators, PV Panel Emulators

Pintor Roig i Soler, 10  
08916, Badalona, BARCELONA  
www.cinergia.coop  
cinergia@cinergia.coop